



- Answer all the following questions
- Illustrate your answers with sketches when necessary.
- The exam. Consists of **two pages**
- No. of questions: 4
- Total Marks: 90 Marks

1. a. Prove, for a single-phase AC regulator feeding a **pure** inductive load that the equivalent inductance seen by the AC source is:

$$L_{eq} = \frac{\pi L}{2(\pi - \alpha) + \sin(2\alpha)}$$

Where L is the load inductance and α is the triggering angle of the thyristor. **(7 Marks)**

b. A three-phase, 380-V, 50-Hz AC regulator feeds a **pure** resistive load. If the value of the output phase voltage is 55 V.

i. Find the triggering angle.

ii. Draw the waveform of the output phase voltage. **(8 Marks)**

2. A single-phase AC regulator feeding an inductive load of $R=10\Omega$ from a 220-V, 50-Hz AC supply. The conduction angle of the thyristor is 180° at a triggering angle of 62.1° , and the extinction angle is 239.3° at a triggering angle of 75° . Find:

i. The inductance value of the load.

ii. The rms value of the load voltage at $\alpha=75^\circ$.

iii. The fundamental power consumed by the load at $\alpha=75^\circ$. **(15 Marks)**

3. a. The flow of power to a resistive load from an ideal sinusoidal supply is controlled by a pair of ideal inverse-parallel connected SCRs. The two switches are gated to produce four cycles of load current followed by four cycles of extinction. Find:

i. The percentage of the output voltage with respect to the supply voltage.

ii. The firing-angle, with phase-angle controlled, to produce the same load voltage. **(10 Marks)**

b. Derive an expression for the average output voltage for a step-up chopper with R-load, assuming that the chopper components are ideal. **(5 Marks)**

c. A boost converter has an input voltage of 5V and a resistive load R. If the required output voltage is 15V and the average load current is 0.5A, the chopper operates at 25 kHz. If the filter parameters are $L=150\mu\text{H}$ and $C=220\mu\text{F}$, determine:

i. Duty cycle.

ii. Ripple inductor current

iii. Peak inductor current

iv. Ripple voltage of the filter capacitor.

v. Derive an expression of the average load voltage, if the inductance is nonideal. **(15 Marks)**

4.a. What are the conditions required to execute dc/dc power electronic converter circuits? **(5 Marks)**

b. What are the important features and applications of the buck-boost converters? **(5 Marks)**

c. Deduce and show the waveforms of the output load voltage, for discontinuous inductor current, for two modes of operation of step-down dc/dc chopper circuit with RLE load. **(10 Marks)**

d. The Cuk regulator has the following parameters: $V_s=12\text{V}$, $D=0.25$, $L_2=150\mu\text{H}$, $C_2=220\mu\text{F}$, $C_1=200\mu\text{F}$, $L_1=180\mu\text{H}$, $I_a=1.25\text{A}$, and $f=25\text{kHz}$. Determine:

i) V_o

ii) I_s

iii) ΔV_{c1}

iv) ΔV_{c2}

v) $L_{1\text{min}}$.

vi) $L_{2\text{min}}$.

(10 Marks)

1- Expressions of a single-phase, AC voltage controller with inductive load

(i) RMS of load voltage

$$V_o = V_s \sqrt{\frac{1}{\pi} \left\{ (\beta - \alpha) + \frac{[\sin 2\alpha - \sin 2\beta]}{2} \right\}}$$

(ii) The fundamental component of load voltage

$$a_1 = \frac{V_m}{2\pi} [\cos 2\alpha - \cos 2\beta]$$

$$b_1 = \frac{V_m}{2\pi} [2(\beta - \alpha) + \sin 2\alpha - \sin 2\beta]$$

$$\theta_1 = \tan^{-1} \frac{a_1}{b_1}$$

2- Expressions RMS of a 3-phase AC regulator feeding a resistive load

$$V_o = V_s \sqrt{\frac{1}{4\pi} \{4\pi - 6\alpha + 3 \sin 2\alpha\}} \quad \dots\dots\dots 0 \leq \alpha \leq \pi/3$$

$$V_o = V_s \sqrt{\frac{1}{2\pi} \left\{ \pi + \frac{3\sqrt{3}}{2} \sin\left(\frac{\pi}{6} + 2\alpha\right) \right\}} \quad \dots\dots\dots \pi/3 \leq \alpha \leq \pi/2$$

$$V_o = V_s \sqrt{\frac{3}{2\pi} \left\{ \frac{5\pi}{6} - \alpha + \frac{1}{2} \sin\left(\frac{\pi}{3} + 2\alpha\right) \right\}} \quad \dots\dots\dots \frac{\pi}{2} \leq \alpha \leq 5\pi/6$$

Where V_s is the rms value of the phase voltage

1. a. Prove, for a single-phase AC regulator feeding a **pure inductive load** that the equivalent inductance seen by the AC source is:

$$L_{eq} = \frac{\pi L}{[2(\pi - \alpha) + \sin(2\alpha)]}$$

Where L is the load inductance and α is the triggering angle of the thyristor.

(7 Marks)

Answer:

$$X_{eq} = \frac{V_s}{I_1} = \frac{V_s}{\left(\frac{V_1}{X_1}\right)} = \frac{V_s X_1}{V_1}$$

$$V_1 = \frac{\sqrt{a_1^2 + b_1^2}}{\sqrt{2}} \quad \& \quad \beta = 2\pi - \alpha$$

$$a_1 = \frac{V_m}{2\pi} [\cos 2\alpha - \cos 2\beta] = \frac{V_m}{2\pi} [\cos 2\alpha - \cos 2(2\pi - \alpha)] = \text{Zero}$$

$$b_1 = \frac{V_m}{2\pi} [2(\beta - \alpha) + \sin 2\alpha - \sin 2\beta]$$

$$= \frac{V_m}{2\pi} [4(\pi - \alpha) + \sin 2\alpha - \sin 2(2\pi - \alpha)]$$

$$= \frac{V_m}{2\pi} [4(\pi - \alpha) + 2\sin 2\alpha]$$

$$= \frac{V_m}{\pi} [2(\pi - \alpha) + \sin 2\alpha]$$

$$\therefore V_1 = \frac{V_s}{\pi} [2(\pi - \alpha) + \sin 2\alpha]$$

$$\therefore X_{eq} = \frac{V_s X_1}{V_1}$$

$$\therefore \omega L_{eq} = \frac{V_s (\omega L) \pi}{V_s [2(\pi - \alpha) + \sin 2\alpha]}$$

$$\therefore L_{eq} = \frac{\pi L}{[2(\pi - \alpha) + \sin 2\alpha]}$$

1. b. A three-phase, 380-V, 50-Hz AC regulator feeds a **pure** resistive load. If the value of the output phase voltage is 55 V.
- Find the triggering angle.
 - Draw the waveform of the output phase voltage.

(8 Marks)

Answer:

i-

$$V_o = 55V \rightarrow \alpha = ?$$

$$\text{at } \alpha = 0^\circ \text{ then } V_o = V_s \sqrt{\frac{1}{4\pi} (4\pi - 6\alpha + 3 \sin 2\alpha)} = 220V$$

$$\text{at } \alpha = \frac{\pi}{3} \text{ then } V_o = V_s \sqrt{\frac{1}{4\pi} (4\pi - 6\alpha + 3 \sin 2\alpha)} = 184V$$

$$\text{at } \alpha = \frac{\pi}{2} \text{ then } V_o = V_s \sqrt{\frac{1}{2\pi} \left(\pi + \frac{3\sqrt{3}}{2} \sin \left(\frac{\pi}{6} + 2\alpha \right) \right)} = 119V$$

$$\text{at } \alpha = \frac{5\pi}{6} \text{ then } V_o = V_s \sqrt{\frac{3}{2\pi} \left(\frac{5\pi}{6} - \alpha + \frac{1}{2} \sin \left(\frac{\pi}{3} + 2\alpha \right) \right)} = 0V$$

$$0 \leq \alpha \leq \frac{\pi}{3}, \quad \frac{\pi}{3} \leq \alpha \leq \frac{\pi}{2}, \quad \frac{\pi}{2} \leq \alpha \leq \frac{5\pi}{6}$$

$$\begin{array}{ccc} \downarrow & & \downarrow \\ 220V \geq V_o \geq 184V & 184V \geq V_o \geq 119V & 119V \geq V_o \geq 0V \end{array}$$

$$\therefore \text{at } V_o = 55V \text{ then } \alpha = 2.0217 \text{ rad} = 115.8349^\circ \approx 116^\circ$$

ii-

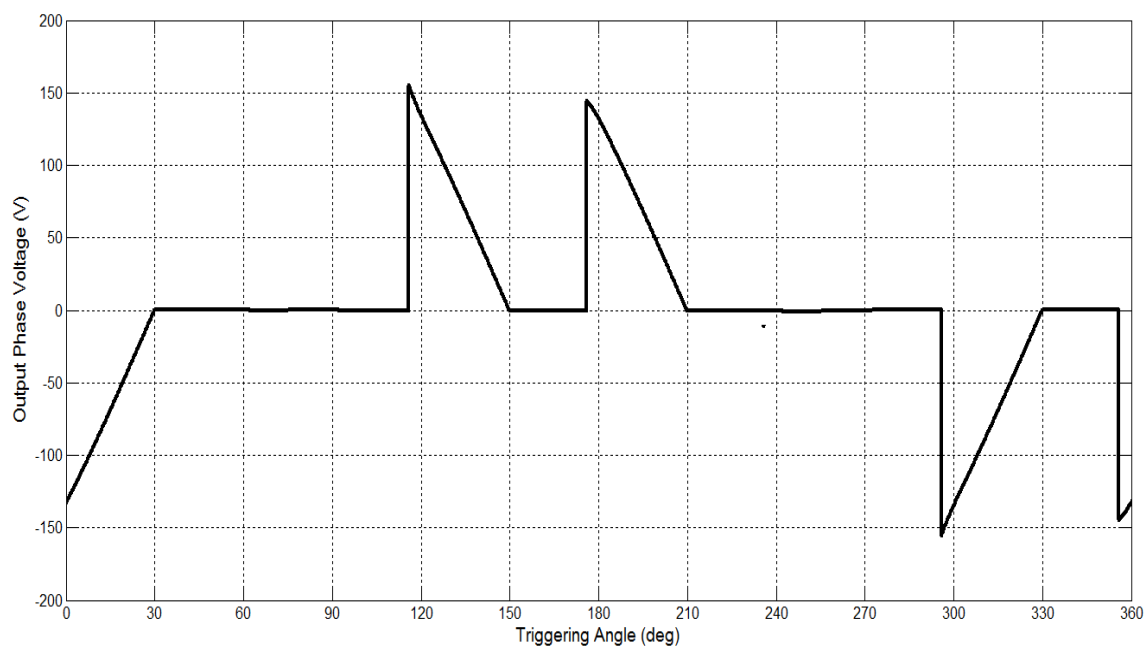

2. A single-phase AC regulator feeding an inductive load of $R=10\Omega$ from a 220-V, 50-Hz AC supply. The conduction angle of the thyristor is 180° at a triggering angle of 62.1° , and the extinction angle is 239.3° at a triggering angle of 75° . Find:

i. The inductance value of the load.

ii. The rms value of the load voltage at $\alpha=75^\circ$.

iii. The fundamental power consumed by the load at $\alpha=75^\circ$.

(15 Marks)

Answer:

$$\because \theta = 180^\circ \quad \therefore \alpha = \phi$$

i-

$$\therefore \phi = 62.1^\circ$$

$$\tan \phi = \frac{\omega L}{R} \quad \rightarrow \quad L = \frac{R \tan \phi}{\omega} = 60mH$$

ii-

$$\because \alpha = 75^\circ \quad , \quad \beta = 239.3^\circ$$

$$\begin{aligned} V_o &= V_s \sqrt{\frac{1}{\pi} \left\{ (\beta - \alpha) + \frac{1}{2} [\sin 2\alpha - \sin 2\beta] \right\}} \\ &= 220 \sqrt{\frac{1}{\pi} \left\{ 2.8676 + \frac{1}{2} [\sin 150 - \sin 478.6] \right\}} \\ &= 203.14V \end{aligned}$$

iii-

$$V_1 = \frac{\sqrt{a_1^2 + b_1^2}}{\sqrt{2}}$$

$$a_1 = \frac{V_m}{2\pi} [\cos 2\alpha - \cos 2\beta] = -19.18$$

$$b_1 = \frac{V_m}{2\pi} [2(\beta - \alpha) + \sin 2\alpha - \sin 2\beta] = 265.275$$

$$\therefore V_1 = 188V$$

$$\therefore I_1 = \frac{V_1}{Z_1} = \frac{188}{\sqrt{10^2 + (2\pi \times 50 \times 0.060)^2}} = 8.81A$$

$$\therefore \theta_1 = \tan^{-1} \frac{a_1}{b_1} = -4.14^\circ$$

$$\therefore P_1 = V_1 I_1 \cos \theta_1 = 1933Watt$$

3. a. The flow of power to a resistive load from an ideal sinusoidal supply is controlled by a pair of ideal inverse-parallel connected SCRs. The two switches are gated to produce four cycles of load current followed by four cycles of extinction. Find:
- The percentage of the output voltage with respect to the supply voltage.
 - The firing-angle, with phase-angle controlled, to produce the same load voltage. **(10 Marks)**

Answer:

$$\therefore n = 4, m = 4$$

i-

$$V_o = \sqrt{K}V_s = \sqrt{\frac{4}{4+4}}V_s = \sqrt{0.5}V_s = 0.707V_s \rightarrow \% \frac{V_o}{V_s} = 70.7\%$$

ii-

$$\frac{\sqrt{0.5}V_s}{R} = \frac{V_s \sqrt{1 - \frac{\alpha}{\pi} + \frac{\sin 2\alpha}{2\pi}}}{R} \rightarrow \alpha = 90^\circ$$

3. b. Derive an expression for the average output voltage for a step-up chopper with R -load, assuming that the chopper components are ideal. **(5 Marks)**

Answer:

For ON – state of the switch :

$$v_s - v_L = 0$$

$$V_s - L \frac{\Delta I_{ON}}{t_{ON}} = 0$$

$$\therefore \Delta I_{ON} = \frac{V_s}{L} t_{ON}$$

For OFF – state of the switch :

$$v_s + v_L - v_o = 0$$

$$V_s + L \frac{\Delta I_{OFF}}{(T - t_{ON})} = V_o$$

$$\therefore \Delta I_{OFF} = \frac{V_o - V_s}{L} (T - t_{ON})$$

$$\therefore \Delta I_{ON} = \Delta I_{OFF}$$

$$\therefore V_o = \frac{V_s}{1 - D}$$

3. c. A boost converter has an input voltage of 5V and a resistive load R . If the required output voltage is 15V and the average load current is 0.5A, the chopper operates at 25 kHz. If the filter parameters are $L=150\mu\text{H}$ and $C=220\mu\text{F}$, determine:

- i. Duty cycle. ii. Ripple inductor current
 iii. Peak inductor current iv. Ripple voltage of the filter capacitor.
 v. Derive an expression of the average load voltage, if the inductance is nonideal. (15 Marks)

Answer:

i-

$$V_o = \frac{V_s}{1-D} \rightarrow D = 1 - \frac{V_s}{V_o} = 1 - \frac{5}{15} = \frac{2}{3}$$

ii-

$$\Delta I_L = \frac{V_s D}{Lf} = \frac{5 \times \frac{2}{3}}{150 \times 10^{-6} \times 25 \times 10^3} = 0.89 \text{ A}$$

iii-

$$I_{L(\text{max})} = I_L + \frac{\Delta I_L}{2} = \frac{V_s}{(1-D)^2 R} + \frac{\Delta I_L}{2} = \frac{5}{(1-\frac{2}{3})^2 \times \frac{15}{0.5}} + \frac{0.89}{2} = 1.945 \text{ A}$$

iv-

$$\Delta V_o = \Delta V_c = \frac{V_o D}{RCf} = \frac{15 \times \frac{2}{3}}{\frac{15}{0.5} \times 220 \times 10^{-6} \times 25 \times 10^3} = 0.0606 \text{ V} = 60.6 \text{ mV}$$

v-

\therefore input power = output power

$$P_i = P_o + P_{\text{loss}}$$

$$V_s I_s = V_o I_o + I_L^2 r_L$$

$$V_s \times \frac{I_o}{1-D} = V_o I_o + \frac{I_o^2}{(1-D)^2} r_L$$

$$\frac{V_s}{1-D} = V_o + \frac{I_o}{(1-D)^2} r_L$$

$$\frac{V_s}{1-D} = V_o + \frac{V_o}{R(1-D)^2} r_L$$

$$\frac{V_s}{1-D} = V_o \left[1 + \frac{r_L}{R(1-D)^2} \right]$$

$$\therefore V_o = \frac{V_s}{(1-D) \left[1 + \frac{r_L}{R(1-D)^2} \right]}$$

4. a. What are the conditions required to execute dc/dc power electronic converter circuits? (5 Marks)

Answer:

- Power electronic devices have high-frequency.
- Regulate the dc output voltage with wide range.
- $V_{in} > \text{or} < V_{out}$
- The transformers, filter inductors, and capacitors used are smaller and lighter.
- The ac voltage ripple on the dc output voltage must be very low.
- Provide isolation between the input source and the load (isolation is not always required).
- Protect the supplied system and the input source from electromagnetic interference (EMI).

4. b. What are the important features and applications of the buck-boost converters? (5 Marks)

Answer:

The important features for the buck-boost converter:

- The gain (D) may be set below or above unity (hence buck-boost converter). The output polarity is opposite to that of the input polarity.
- The gain is independent of the switching frequency so long as $(TS \ll RC)$. However this design inequality is a function of the load.
- The output voltage ripple percentage is dependent on the load on the converter. The output ripple has a first order roll-off with the switching frequency.
- In practice buck-boost converters are not operated beyond a duty ratio of about 1/2 to 2/3.
- The efficiency of power conversion is good when and $RL; R_g \ll R; V_{sn} \ll V_g; V_{sf} \ll V_o$ at low duty ratios.
- f. The input current is discontinuous and pulsating. It will therefore be necessary to have an input filter also with buck-boost converter, if the source is not capable of supplying such pulsating current.
- The applications of the buck-boost converter:
- Switch mode power supplies (SMPS), Uninterruptable power supplies (UPS), wind turbine charging a battery bank, 3- Smart grid, class c for dc drives.

4. c. Deduce and show the waveforms of the output load voltage, for discontinuous inductor current, for two modes of operation of step-down dc/dc chopper circuit with RLE load. (10 Marks)

Step-down dc/dc chopper circuit with RLE load.

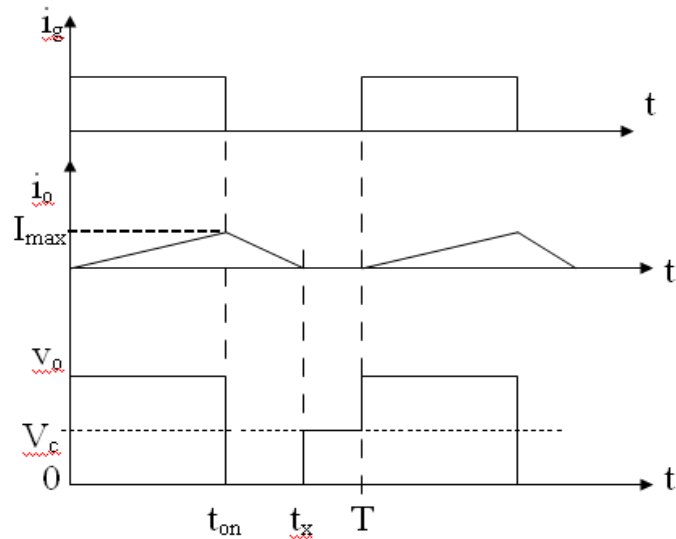
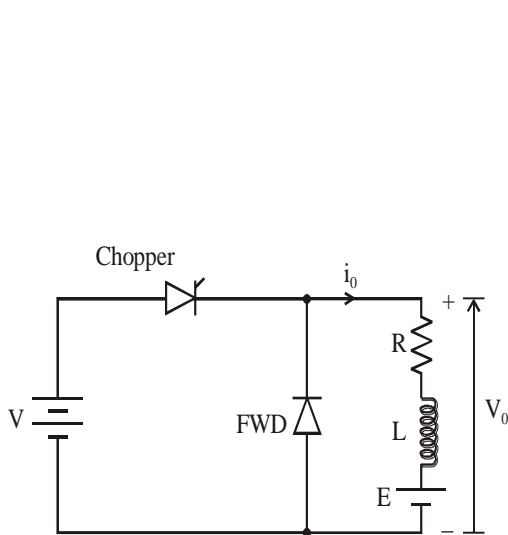

The output load dc voltage

$$V = i_o R + L \left(\frac{di_o}{dt} \right) + E$$

$$V_o = V_a = \frac{1}{T} \left[\int_0^{t_{on}} V_s dt + \int_{t_{on}}^T 0 dt \right]$$

$$= V_s \left(\frac{t_{on}}{T} \right) = f t_{on} V_s$$

$$= V_s d, \text{ the range of } V_o (0 \rightarrow V_s)$$

Function of the dc-dc converter

$$d = \frac{V_o}{V_s} = \text{duty cycle of switch} \quad (0 \rightarrow 1)$$

▪ The r.m.s value of output voltage is:

$$V_{o(rms)} = \sqrt{\left(\frac{1}{T} \int_0^T v_o^2 dt \right)} = V_s \sqrt{d}$$

In case of discontinuous load current,

$$I_{min} = \frac{V}{R} \left[\frac{e^{dRT/L} - 1}{e^{RT/L} - 1} \right] - \frac{E}{R} = 0$$

$$\frac{V_c}{V_s} = \frac{e^{(t_{on}^x/\tau)(T/\tau)} - 1}{e^{T/\tau} - 1} \quad \text{Or} \quad \frac{E}{V_s} = m = (e^{\rho\sigma} - 1) / (e^\sigma - 1)$$

$$\rho = \frac{t_{on}^x}{T} = D^\alpha, \quad \sigma = \frac{T}{\tau}$$

$$m = (e^{\rho\sigma} - 1) / (e^\sigma - 1)$$

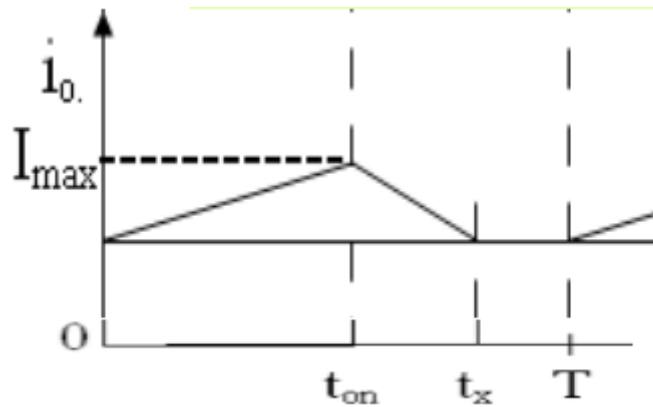
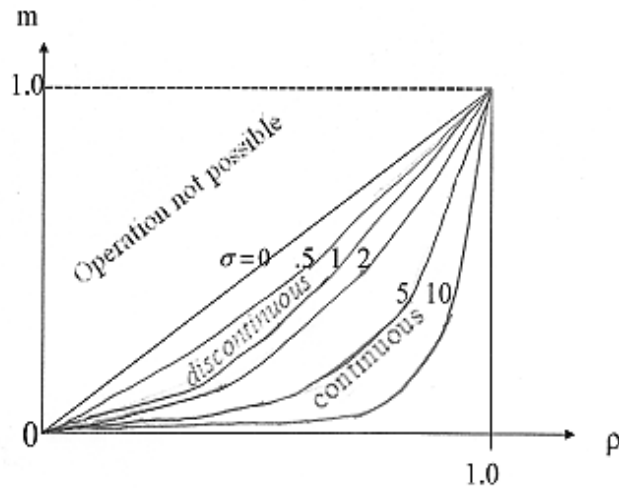

at $t = t_x$, $t^* = t_x - t_{on}$ the value $I_{min} = \text{zero}$

$$I_p = \frac{V_s - V_c}{R} (1 - e^{-t_{on}/\tau}) \quad (0 \leq t_{on} < t_{on}^x)$$

$$i_a = -\frac{V_c}{R} (1 - e^{-t^*/\tau}) + I_p e^{-t^*/\tau} \quad (0 \leq t_{on} < t_{on}^x)$$

$$t^* = \frac{L}{RT} \ln \left[1 + \frac{E}{V} (e^{\pi T/L} - 1) \right]$$

$$t_x = t_{on} + t^*$$

$$t_x = t_{on} + \tau \ln \left\{ e^{t_{on}/\tau} \left[1 + \frac{V_s - V_c}{V_c} (1 - e^{-t_{on}/\tau}) \right] \right\}$$

4. d. The Cùk regulator has the following parameters: $V_s=12V$, $D=0.25$, $L_2 =150\mu H$, $C_2=220\mu F$, $C_1=200\mu F$, $L_1=180\mu H$, $I_a=1.25A$, and $f= 25kHz$. Determine:

i) V_o

ii) I_s

iii) Δv_{c1}

iv) Δv_{c2}

v) L_{1min}

vi) L_{2min}

(10 Marks)

Answer:

$$i) V_o = - DV_s / (1-D)$$

$$V_o = - 4V$$

$$ii) \frac{I_{L1}}{I_{L2}} = - \frac{V_o}{V_s}$$

$$I_s = 0.42A$$

$$iii) \Delta v_{c1} = \frac{1-D}{8L_2C_2f^2} = 63mV$$

$$iv) \Delta v_{c2} = \frac{V(1-D)}{8C_2L_2f^2} = 18.18mV$$

$$v) L_{1min} = \frac{(1-D)^2 R}{2Df} = 0.54 mH$$

$$vi) L_{2min} = \frac{(1-D) R}{2f} = 0.18 mH$$